

### Metro Oval MEDICINE CABINET

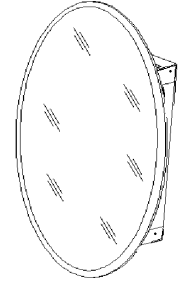

#### FEATURES/TYPICAL SPECIFICATIONS

- Recessed mount installation
  - Wall Opening/Rough-in dimensions: 14 $\frac{1}{4}$ " x 18" x 3 $\frac{1}{2}$ "
- Formed and welded steel housing construction (WB/ST)
  - 22 gauge hinge plate welded to steel housing
  - 24 gauge steel with white, heat cured, acrylic paint finish
  - 1/8" thick float glass mirror with polished edges on housing back
- Frameless mirror door
  - 3/16" thick float glass oval mirror front with 1" beveled edge
  - 23 gauge steel door back with white, heat cured, acrylic paint finish
- 8 $\frac{1}{8}$ " piano hinge (HG01) (1 typical)
  - Hinge half welded to the door back
  - Hinge half welded to the hinge plate on the housing
  - The hinge pin joins the two hinge halves, connecting the door with the housing
- Magnetic catch in cabinet body flange aligns to stainless steel striker plate on door (1 typical)
- Reversible for left-hand or right-hand door swing
- 3/16" thick float glass shelves, adjustable (ADJ) (2 typical)
- Snap Fit plastic shelf supports (8 typical)
- Mounting hardware included
- Standard Pallet Quantity of 24 units

#### Finishes:

Housing: PT01—Basic White  
 Mirror: 1 BVL—1" Bevel Edge  
 Frame: Frameless

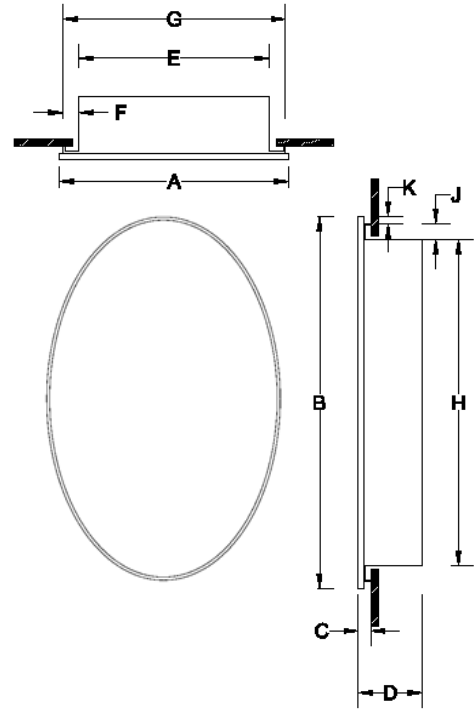

		Dimensions In Inches									
Model #	Description	A	B	C	D	E	F	G	H	J	K
52WH184PV	MEDCAB 1DR 21X31 FMLS WB/ST	21 $\frac{1}{4}$	31 $\frac{1}{4}$	1 $\frac{1}{8}$	4 $\frac{1}{2}$	13 $\frac{1}{2}$	1	15 $\frac{1}{2}$	17 $\frac{1}{2}$	1	5 $\frac{1}{8}$

REFERENCE	QTY.	REMARKS	Project
			Location
			Architect
			Engineer
			Contractor
			Submitted by
			Date

\* All models and material specifications are subject to change or withdrawal without notice.